

## Behavior of Reinforced Concrete Beams Strengthened by GFRP Composites Subjected to Combined Bending and Torsion – Experimental study

Nageh N. Meleka<sup>1</sup>, Khaled M. Heiza<sup>1</sup>, Ahmed Nabil<sup>1</sup>, and Islam M. Othman<sup>2</sup>

<sup>1</sup>*Civil Engineering Department, Faculty of Eng., Menoufia University, Egypt.*

<sup>2</sup>*Department of Civil Eng., Higher Institute of Engineering and Technology, Kafr Elsheikh,, Egypt, PhD Candidate, Civil Engineering Department, Faculty of Eng., Menoufia University, Egypt.*

### ABSTRACT

This paper presents an experimental investigation on the behavior of reinforced concrete beams subjected to combined bending and torsion, strengthened by using externally bonded glass fiber reinforced polymer (GFRP). The experimental work includes investigation of three RC beams tested under combined bending and torsion. One beam is kept without strengthening as a control specimen, while the other two beams are strengthened using GFRP wrapping with different configurations. All RC beams have the same concrete grade and steel reinforcement. The strengthened beams in the experimental study include full wrapping with continuous GFRP sheets and discrete GFRP strips with the same GFRP reinforcement ratio. The load-mid span deflection curves and the torsional moment-twist angle curves were recorded to failure. The crack patterns and failure modes of the RC beams were also indicated. The Experimental results reveal that strengthening by using GFRP wrapping helped effectively in improving the overall performance of the strengthened beams.

**Keywords:** Reinforced concrete beam; Glass fiber reinforced polymer (GFRP); Strengthening techniques; Torsion; Bending.

### 1. Introduction

Structural members in many reinforced concrete (RC) buildings and bridges such as spandrel beams, eccentrically loaded beams, edge beams of shell roofs, spiral staircases and horizontally curved members are subjected to significant torsion with a combination of shear or flexure or a combination with both. Reinforced concrete members may have a deficiency in torsional capacity and need strengthening [1, 2].

Hii and Al-Mahaidi [3] carried out experimental and numerical investigation of six beams solid and box sections strengthened using carbon fiber reinforced polymer (CFRP) strip wrapping tested under pure torsion. Ameli et al. [4] carried out an experimental and numerical study of twelve rectangular RC beams strengthened by GFRP / CFRP wrap with different configuration tested under pure torsion. Chalioris [5] evaluated the effectiveness of the use of epoxy-bonded carbon FRP fabrics as external transverse reinforcement in beams without steel stirrups by testing 14 rectangular and T-shaped beams under pure torsion. Mohammadizadeh and Fadaee [6] carried out an experimental and analytical study on seven rectangular high-strength concrete (HSC) beams strengthened by CFRP sheets tested under pure

torsion. Jariwala et al. [7] carried out experimental study for the improvement of the torsional resistance of reinforced concrete beams using GFRP wrapping of different configuration by testing 14 RC beams under combined effect of torsion and bending. Deifalla et al. [8] investigated the behavior of FRP externally strengthened flanged beams subjected to torsion by testing eleven beams under significant torsion. Tibhe and Rathi [9] carried out an experimental study dealing with the strengthening of reinforcing concrete beams in torsion using GFRP/CFRP fabric as external reinforcement. Meleka et al. [10] carried out an experimental study for the improvement of the torsional behavior of reinforced self-compact concrete beams using GFRP wrapping of different configuration by testing eleven RC beams under pure torsion. Atea [11] presented an experimental investigation of the effectiveness of using carbon fiber reinforced polymer (CFRP) as externally bonded reinforcement by testing twelve reinforced concrete T-beams under pure torsion. Kandekar and Talikoti [12] evaluated the effectiveness of the use of aramid fiber as an externally bonded reinforcement by testing a total of 12 RC rectangular beams under torsional moment. Hadhood et al. [13] evaluated the effectiveness of using GFRP rectangular spirals and

rectilinear stirrups to reinforce concrete beams in the transverse direction under pure torsion.

## 2. Aim and Research Significance

This study aims to evaluate the effectiveness of using GFRP wrapping with different configuration (fully wrapping with continuous sheets and wrapping strips) in improving the overall performance of the RC beams subjected to combined bending and torsion.

## 3. Experimental Program

### 3.1. Specimen Details

The experimental program includes three rectangular reinforced concrete beams that were cast and tested in the laboratory under combined torsion and bending. Two beams (BGF2 and BGS4) were strengthened using externally bonded GFRP as external transverse reinforcement and one beam (BC) served as a control beam. All beams were 150 x 300 mm in cross section, the total length of the beams was 2200 mm and the length of the test region was 800 mm at the middle part of the beams. The beams were reinforced with three 16 mm diameter deformed longitudinal bars as tension reinforcement and two 12 mm diameter deformed longitudinal bars as compression reinforcement. The beams were reinforced with closed vertical stirrups in the transverse direction with 8 mm diameter spaced at 200 mm c/c, in the test region. The end zones of 0.5 m long on each end of the beam were properly over reinforced in shear with high volume of vertical

stirrups with 10 mm diameter spaced at 100 mm c/c to force the failure in the test region. Each beam includes two cantilevers in order to produce the torsional moment, having a cross section of 200 mm × 300 mm. The two cantilevers were reinforced with three 16 mm deformed longitudinal bars at the top, three 12 mm deformed longitudinal bars at the bottom and vertical stirrups in the transverse direction with 10 mm diameter spaced at 80 mm c/c. The dimensions and the reinforcement details of test beams are shown in Fig. 1. For the strengthened beams (BGF2 and BGS4), the beam (BGF2) was strengthened using two layers of continuous GFRP sheets. These sheets were wrapped around the rectangular cross-section along of the length of the test region and the other strengthened beam BGS4 was wrapped using a 100 mm (four layers) wide GFRP strips around the perimeter of the cross-section spaced at 200 mm c/c along the length of the test region. The different wrapping configurations are shown in Fig. 2 and summarized in Table 1. The strengthened beams had the same GFRP Reinforcement Ratio (P) and calculated based on the following Eq. (1):

$$P = \frac{N_f \times T_f \times P_f \times W_f}{A_c \times S_f} \quad (1)$$

Where:  $A_c$  is gross area of the concrete cross-section;  $N_f$  is number of FRP layers;  $T_f$  is thickness of the FRP with resin = 1.2 mm / layer and without resin = 0.28 mm / layer;  $S_f$  is spacing of the FRP strips;  $W_f$  is width of FRP strips;  $P_f$  is perimeter of the strengthened beam cross-section using FRP fabrics = 2 (h + b).

Table 1. Test beams details.

Beam Code	Types of Strengthening	No. of Layers $N_f$	Width of Layer $W_f$ (mm)	Spacing Between Strips $S_f$ (mm)	GFRP Reinforcement Ratio P (%)
BC	—	—	—	—	—
BGS4	Full Wrapping with strips	4	100	200	1.12
BGF2	Full Wrapping with continuous sheets	2	800	—	1.12

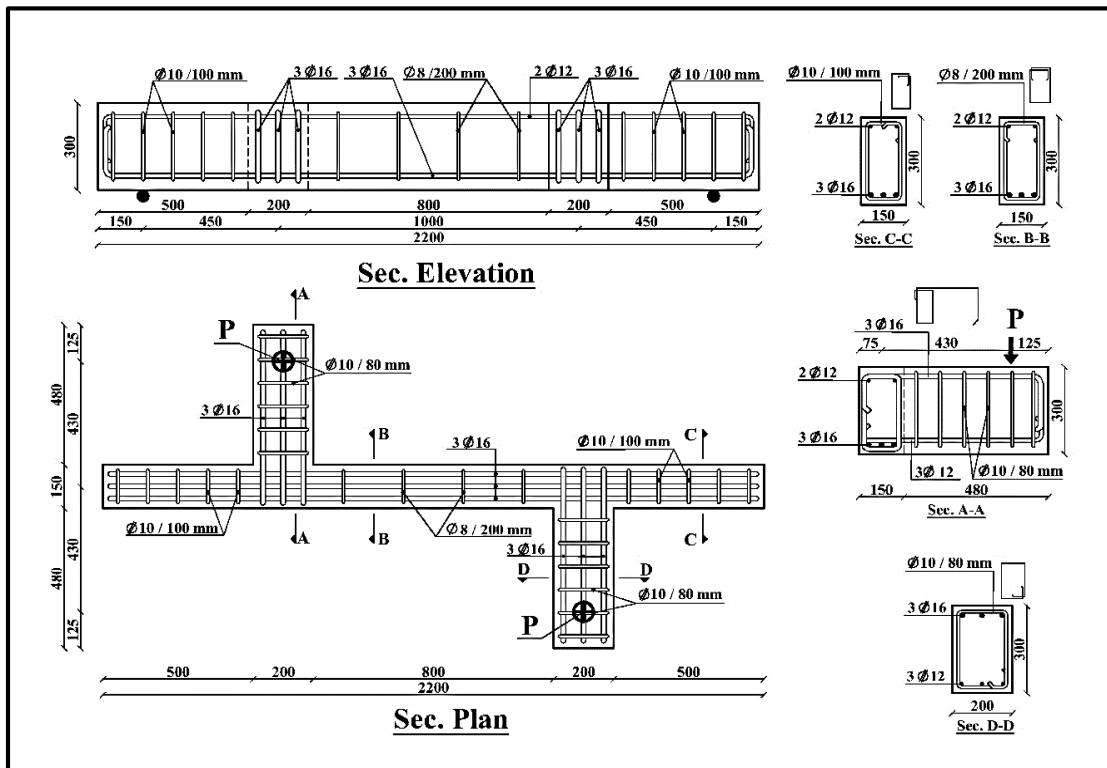

Fig. 1. Dimensions and reinforcement details of test beam.

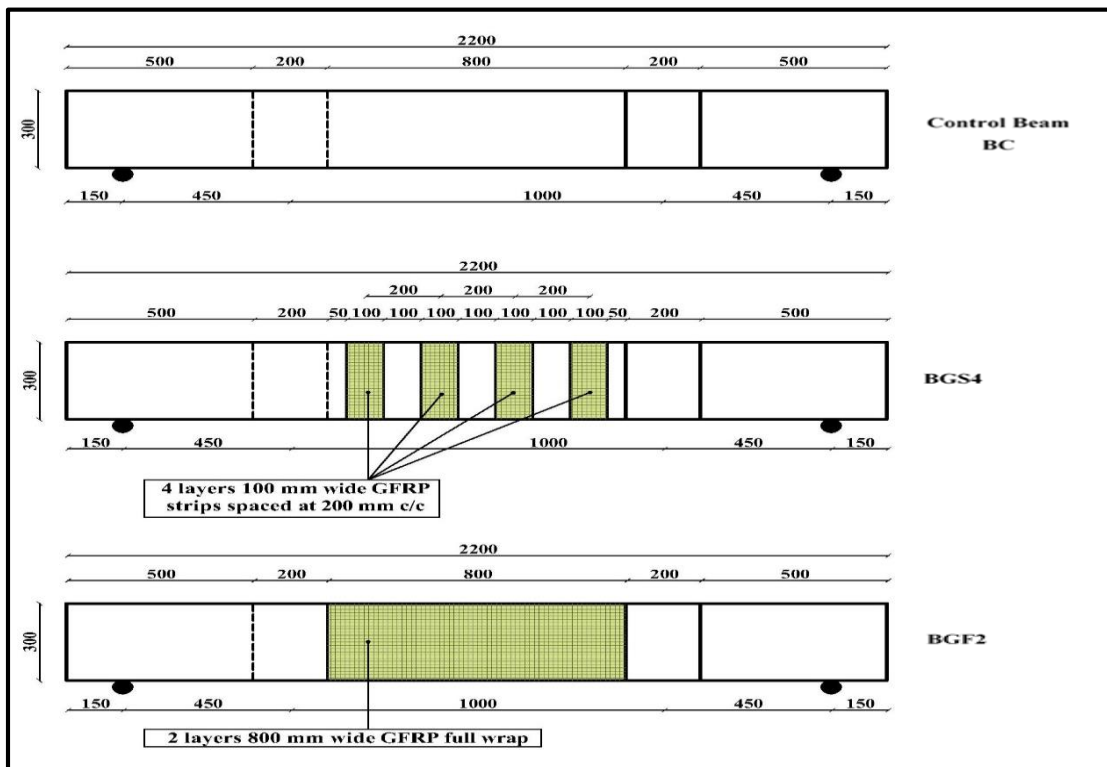

Fig. 2. Schematic representation of different wrapping configurations.

**3.2. Material properties**

All specimens were cast using ready-mixed concrete. After curing specimens for 28 day, the standard cube compressive strength achieved 26 MPa. The yield strength ( $f_y$ ) for the deformed longitudinal bars was 368 MPa. The yield strengths of the vertical stirrups with 8 mm and 10 mm diameter were 254 MPa and 368 MPa, respectively. Polyester was used as a resin and the peroxide was used as a hardener approximately 3 % by the total volume of polyester to bond the glass fabrics over the specimens. The glass-fiber sheets used in this study were bi-directional woven wrap (Jushi-EWR600). The mechanical properties of this fiber are shown in Table 2.

**3.3. Test setup and instrumentation**

All beam specimens were tested under combined bending and torsion, and that by exposing the beams to a concentrated load using a hydraulic actuator with a capacity of 450 kN, the concentrated load is transferred to specimen through steel spreader beam placed diagonally and resting on the ends of two

cantilevers arms. So, half of the applied concentrated load will feat at the end of each cantilever arm. Since the load at the end of cantilever arm is at a distance of 430 mm from the longitudinal axis of the beam and about 450 mm from the center of beam supports, it will lead to a combination of bending and torsion in the middle part of the beam. Fig. 3 shows the internal forces in the test specimens. Two hinged supports are also prepared to allow the beam specimen to rotate around its longitudinal axis. Linear variable displacement transducers (LVDTs) were used for measuring the vertical displacements in the test, the twist angle of each cantilever arm is obtained from the vertical displacement and cantilever arm length. Two LVDTs are placed at the end of cantilevers arms under the load impact points, two LVDTs are placed at a distance of 450 mm from the center of two supports and one LVDT located at mid span of the beam. The readings of the LVDTs were recorded for every load increase by a computer-controlled data procurement system. Details of setup and instrumentations are shown in Fig. 4.

Table 2. The mechanical properties of glass fibers.

Type of Fiber	Total wt. (g/m <sup>2</sup> )	Modulus of Elasticity (MPa)	Ultimate Tensile Strength (MPa)	Ultimate Tensile Elongation
GFRP woven wrap	600	51700	2415	4.6 %

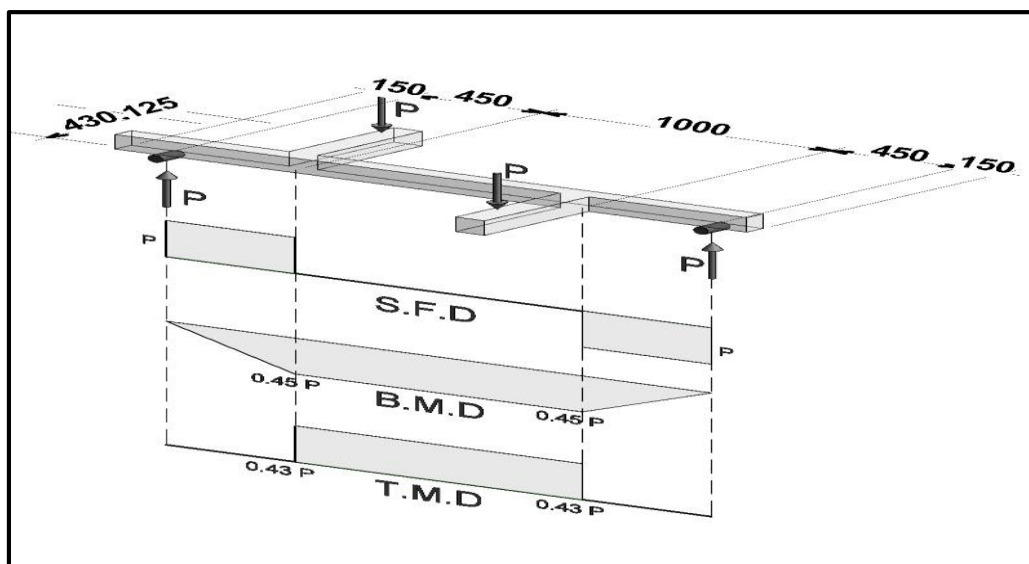

Fig. 3. Internal force diagram for specimen under combined bending and torsion.

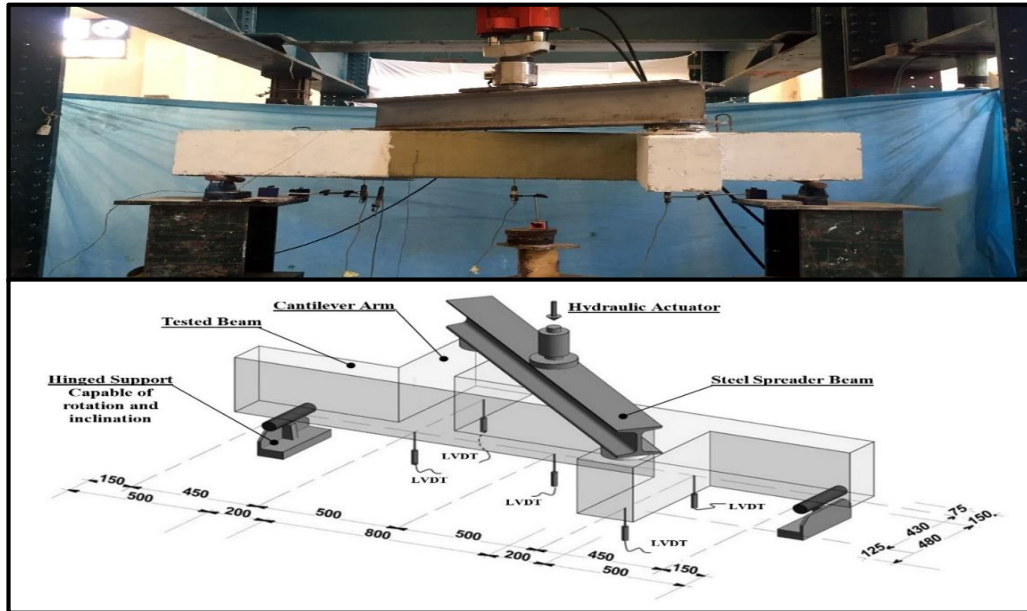

Fig. 4. Test setup and instrumentation.

**4. Test Results and Discussions**

**4.1. Torsional strength values and behavior curves**

The cracking torsional moment ( $T_{cr}$ ), the ultimate torsional moment ( $T_u$ ) and the ultimate twist angle per unit length are summarized in Table 3. The torsional moment versus angle of twist per unit length for all tested beams are plotted in Fig. 5. The strengthened beams (BGS4, BGF2) with GFRP sheets exhibited significantly increase in both cracking and ultimate torsional capacity as well as maximum twist deformations compared to the control beam (BC). A significant increase in both cracking and ultimate torsional capacity for beam BGF2 of 76.6% and 165.08%, respectively. As well as an increase in both cracking and ultimate torsional capacity for beam BGS4 by 44.54% and 102%, respectively. For all specimens, the deformational behavior was approximately constant in early loading stages up to a twist angle of about 0.00384 rad/m and then increased

gradually until failure. At the same loading level, the twist angles of the strengthened beams was smaller than the twist angle of control beams. The ultimate twist angle of both strengthened beams (BGS4, BGF2) increased by 125.4% and 178.1%, respectively compared to the corresponding control beam. It was observed that, fully wrapped beam BGF2 with two layers of continuous GFRP sheets exhibited higher torsional upgrade efficiency than the specimen BGS4 that was strengthened using four layers of discrete GFRP strips, although that both beams had the same fiber reinforcement ratio (1.12%). This is due to the different failure processes of these tested beams. BGS4, cracks occur between the discrete strips and then are opened. On the contrary, BGF2 did not show similar behavior because the cracks are not allowed to open due to the resistance provided by the fibers

Table 3. Summary of results.

Specimen	$T_{cr}$ (kN.m)	$T_u$ (kN.m)	Cracking Increase (%)	Ultimate Increase (%)	Ultimate Twist Angle (rad/m)
BC	4.171	6.34	—	—	0.0302
BGS4	6.03	12.81	44.54	102	0.0680
BGE2	7.366	16.81	76.6	165.08	0.0840

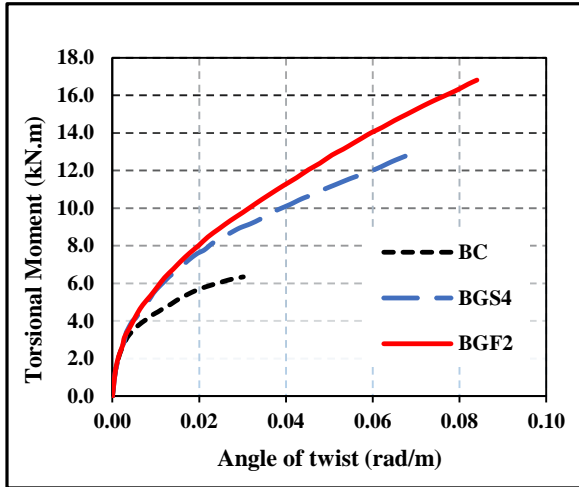

Fig. 5. The torsional moment versus angle of twist per unit length.

**4.2. The flexural stiffness**

The flexural stiffness of the strengthened beams (BGS4, BGF2) is compared with the control beam (BC). This comparison is done through the relationship between the load and the deflection at mid-span as shown in Fig. 6. This relationship shows that the stiffness of all tested beams remains unchanged in the initial stages of loading and an increase in the flexural stiffness of the strengthened beams (BGS4, BGF2) compared with the corresponding control beam (BC) with the appearance of cracks and reaching to the ultimate stages of loading until failure.

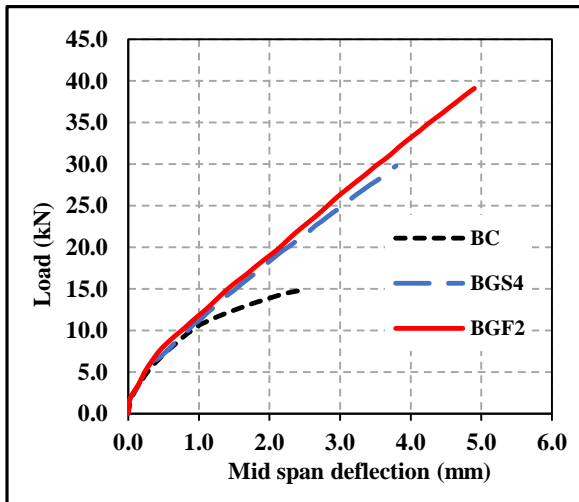
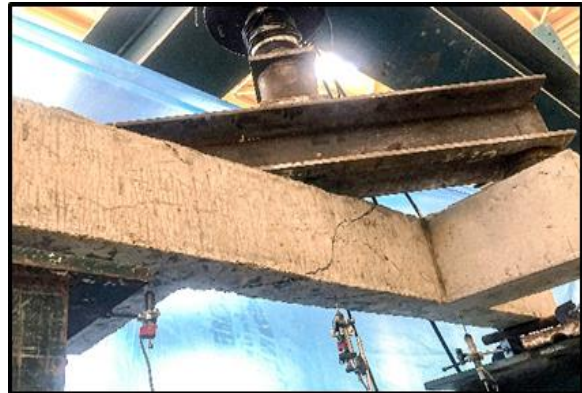

Fig. 6. Load versus Mid span deflection.

**4.3. Crack patterns and failure modes**

All tested beams showed typical torsional failures modes as shown in Fig. 7. Spiral diagonal cracks appeared at the middle part of beams, which are subject to combined bending and torsion. The control beam BC exhibited a wider range of crack spreading compared to the strengthened beams because there is no fibers inhibited crack spreading. For the strengthened beam BGS4 wrapped with GFRP strips, the failure was partially delayed compared to the failure of the control beam as fiber prevented the formation of cracks, but eventually diagonal cracks initiated and gradually widened as load increased in the unwrapped concrete parts between the strips . The failure of fully wrapped beam (BGF2) with continuous GFRP sheets exhibited an extensive concrete cracking inside the wrapping more than the other tested beams because the failure occurred at a high level of loading. For all the strengthened beams, no fiber rupture or debonding was detected along the test region of beams.



(a)

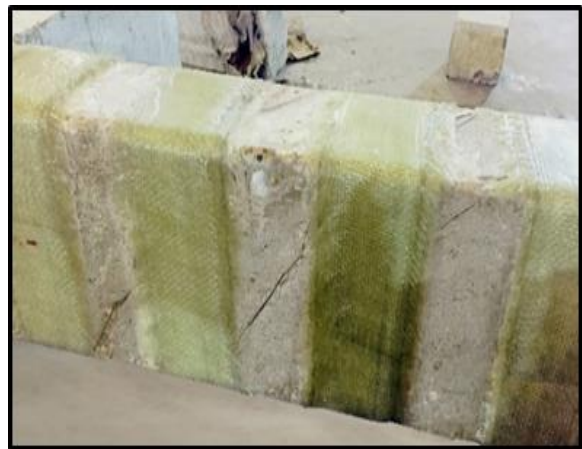

(b)





(c)

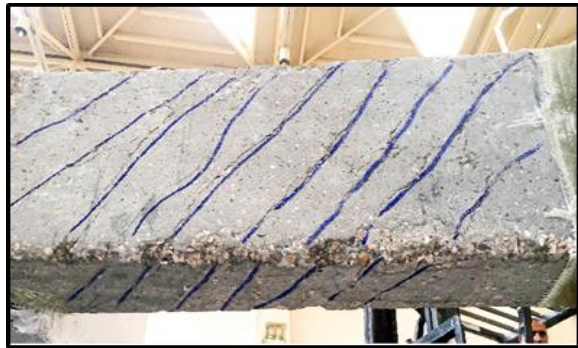

(d)

Fig. 7. Mode of failures for specimens tested under combined bending and torsion.

- (a) Control specimen (BC) (b, c) Specimen (BGS4) Full wrapping with strips  
(d) Specimen (BGF2) Full wrapping with continuous sheet

### 5. Conclusions

The experimental work conducted in this work involved the testing of three rectangular cross section reinforced concrete beams under combined bending and torsion. The main objective of this work was to evaluate the efficiency of using GFRP wraps as external transverse reinforcement. Based on the test results obtained from the experimental study, the following conclusions are summarized below:

1. Using GFRP wrapping as external transverse reinforcement helped effectively in improving the overall performance of the strengthened beams.
2. The strengthening using full wrapping with continuous GFRP sheets is far more efficient for torsional upgrading than the use of wrapping with the same fiber reinforcement ratio of discrete strips.
3. Strengthening beams with GFRP full wraps helped effectively in improving the ultimate

torsional capacity of beams up to 165.08% compared to the control beam.

4. Strengthening beams with GFRP full wraps helped effectively in improving the cracking torsional moment of beams up to 76.6% compared to the control beam.
5. The flexural stiffness of all tested beams remains unchanged in the initial stages of loading. On the other hand, an increase in the stiffness was observed in the strengthened beams at higher loading levels.

### 7. References

- [1] Heiza K., Nabil A., Meleka N. and Tayel M. "State-of-the Art Review: Strengthening of Reinforced Concrete Structures – Different Strengthening Techniques", Sixth International Conference on Nano - Technology in Construction, 2014, pp. 1-24
- [2] Meleka N. N., Heiza K. M., Elwakkad N. Y. and Othman I. M. "State-of-the Art Review: Torsional Behavior of RC Beams strengthened by FRP systems", Menoufia University, Faculty of Engineering, First International Conference (Ninth Conference of Sustainable Environmental Development), 24-28 March 2017, pp. 1-19.
- [3] Hii A. K. Y. and Al-Mahaidi R. "An Experimental and Numerical Investigation on Torsional Strengthening of Solid and Box-Section RC Beams Using CFRP Laminates", Elsevier, Composite Structures 75, 2006, pp. 213-221.
- [4] Ameli M., Ronagh H. R. and Dux P. F. "Behavior of FRP Strengthened Reinforced Concrete Beams under Torsion", ASCE, Journal of Composites for Construction, Vol. 11, No. 2, April, 2007, pp. 192-200.
- [5] Chalioris C. E. "Torsional Strengthening of Rectangular and Flanged Beams Using Carbon Fibre-Reinforced-Polymers-Experimental Study", Elsevier, Construction and Building Materials 22, 2008, pp. 21-29 .
- [6] Mohammadzadeh M. R. and Fadaee M.J. "Torsional Behaviour of High-Strength Concrete Beams Strengthened Using CFRP Sheets; an Experimental and Analytical Study", Scientia Iranica, Vol. 16, No. 4, August, 2009, pp. 321-330.
- [7] Jariwala V. H., Pate P. V., and Purohit S. P. "Strengthening of RC Beams Subjected to Combined Torsion and Bending with GFRP Composites", Elsevier, Procedia Engineering 51, 2013, pp. 282-289.

- [8] Deifalla A., Awad A., Elgarhy M. "Effectiveness of Externally Bonded CFRP Strips for Strengthening Flanged Beams Under Torsion: An Experimental Study", *Engineering Structures* 56, 2013, pp. 2065–2075.
- [9] Tibhe S. B. and Rathi V. R., "Comparative Experimental Study on Torsional Behavior of RC beam using CFRP and GFRP Fabric Wrapping", *Procedia Technology* 24, 2016, pp. 140 – 147.
- [10] Meleka N. N., Heiza K. M. and Othman I. M. "Torsional Behavior of Self Compacted Concrete Beams Strengthened by FRP Systems", *Menoufia University, Faculty of Engineering, First International Conference (Ninth Conference of Sustainable Environmental Development)*, 24-28 March 2017, pp. 1-37.
- [11] Atea R. S. "Torsional Behavior of Reinforced Concrete T-Beams Strengthened with CFRP Strips", *Case Studies in Construction Materials* 7, 2017, pp. 110-127.
- [12] Kandekar S. B. and Talikoti R. S., "Torsional Behaviour of Reinforced Concrete Beam Wrapped with Aramid Fiber", *Journal of King Saud University – Engineering Sciences* 31, 2019, pp. 340-344.
- [13] Hadhood A., Gouda M. G., Agamy M. H., Mohamed H. M. and Sherif A., "Torsion in Concrete Beams Reinforced with GFRP Spirals", *Engineering Structures* 206, 2020.