

CONTROL TECHNIQUES FOR LOSSES REDUCTION IN WIND TURBINE DOUBLY-FED INDUCTION GENERATOR

Ahmed S. Serry¹, Medhat H. El-Far², Ahmed E. Kalas³ and Fathy E. Abdel-Kader⁴

^{1,2,3}Electrical Engineering Dept., Faculty of Engineering, Port-Said, Port-Said University, Egypt

⁴Electrical Engineering Dept., Faculty of Engineering, Shebin El-Kom, Minoufiya University, Egypt

ABSTRACT

This paper presents the performance of different reactive power control strategies for reduction of the losses in doubly-fed induction generator (DFIG) drives. The proposed strategy achieves its goal through controlling the decoupled active and reactive power flow in the machine and in the converters. Considering the machine-copper losses, converters loss and filter loss, the proposed method is derived. The modeling of the DFIG-based wind turbine along with its control strategy is designed using Matlab/Simulink environment and the results show the effectiveness of the proposed control strategy.

يقدم هذا البحث أداء طرق مختلفة للتحكم في القدرة الغير فعالة لتقليل المفايد في المولد الحثي ذو التغذية الثنائية لطواحين الهواء. الطريقة المقترحة تحقق هدفها من خلال التحكم في التدفق المنفصل لكل من القدرة الفعالة والقدرة الغير فعالة في الآله وفي المغير. و بالأخذ في الاعتبار المفايد النحاسية للآلة ومفايد المغير ومفايد المرشح تم اثبات الطريقة المقترحة. وعليه فقد تم تصميم نموذج الآله ونظام التحكم باستخدام نظام المحاكاه بالماتلاب وتبين النتائج مدى فعالية طريقة التحكم المقترحة.

Keywords: Wind Energy; doubly fed induction generator (DFIG); reactive power control; loss-minimization.

1. INTRODUCTION

Most of the electricity generated today uses non-renewable sources of fuel such as coal, oil and gas. These contribute to large quantities of CO₂ to the atmosphere, and cause an enhanced greenhouse effect, leading to the warming of the earth's atmosphere. The increasing rate of depletion of conventional energy sources has increased emphasis on renewable energy sources to provide the growing demand. The adverse effects of conventional systems have given rise to a shift in focus towards renewable energy sources such as wind, solar, hydro, tidal wave, biomass, and so on. As already known, renewable energy sources have virtually no adverse effects on the environment [1].

The Global Wind Energy Council (GWEC) states that the installed wind power capacity has been progressively growing over the last two decades. The installed capacity of global wind power has increased exponentially from approximately 6 GW in 1996 to 282 GW by 2012. The wind industry has achieved an average growth rate of over 28% for the past fifteen years, and is expected to continue this trend in the coming years [2]. This impressive growth has been

spurred by the continuous cost increase of classic energy sources, cost reduction of wind turbines, governmental incentive programs, and public demand for cleaner energy sources.

Due to the highly variable wind velocity, variable speed constant frequency (VSCF) wind generation system has distinct advantages than the traditional constant speed constant frequency (CSCF) wind generation system, such as more effective power capture, lower mechanical stress and less power fluctuation. Three main types of VSCF wind power conversion system are usually adopted in the world, such as directly driven synchronous generators, squirrel cage induction generators and doubly fed induction generators (DFIG) [3]. The doubly-fed induction generator (DFIG) presents some remarkable advantages as a generator for MW-class wind energy converters (WECS). It is worthy to mention the achievable speed range with power electronics converters with part of the rated power. By regulating the slip power flow through the rotor circuit the machine is controlled over the synchronous operating point in a range proportional to the slip. Hence a back-to-back converter with 1/3 of the rated power is required, which in turn signifies lower prices, less losses and less harmonic contents. Nevertheless the

DFIG is the most used generator in the nowadays implanted wind turbines [4].

The re-powering of existing power plants and the under-going and planned massive construction of offshore power plants with high-powered generators in the range of 5 MW makes efficiency a very important issue. This paper proposes control strategies in order to minimize losses, increasing the overall efficiency. A very important feature is that existing control structures could be easily adapted, mostly just by software programming and without further hardware acquisition, in order to pursue this aim. In order to improve the overall efficiency of the wind energy conversion some methods for minimizing the electrical losses on the generator and on the converters were proposed in previous works. These methods deal with the reactive power flow controlled by the inverters simultaneously to the active power control [5].

Regulating the reactive power flow in order to minimize losses was addressed [3-10]. In [4-8], the required reactive power on the generator and on the supply is shared between the inverters on the rotor and on the net side in order to achieve the optimal efficiency over the operating range. This technique is not feasible since it requires large sets of look-up tables, and further, it does not give reasonable results with large rating machines. In [9], the grid-side converter was used for inject the required reactive power to regulate terminal voltage and by setting the reactive reference control component of the rotor-side converter. The copper losses of the DFIG are modeled as a function of the stator flux and d-axis current. Then, a stator d-axis current which minimizes the total generator losses was derived in [10]. The optimal rotor reactive current value was derived for minimal machine copper losses in [3]. Finally in [10], also, an optimal rotor reactive current value was derived but for minimal overall losses.

In this paper, the main goal of the proposed optimal strategy of DFIG is to choose the operating points depending on the condition of overall loss-minimized operation of DFIG. The total losses are minimized by optimal rotor reactive current. The following sections introduce the modeling and control structure used to achieve this goal as well as the loss modeling in order to compute the system losses.

2. SYSTEM TOPOLOGY AND CONTROL STRUCTURE

In modern DFIG drives the variable voltage and frequency rotor circuit are connected to the constant voltage and frequency grid by a back to back converter composed of two conventional pulse width modulated (PWM) voltage-source converters, linked through a DC capacitor. The stator circuit is directly connected to the three phase grid/load. The rotor-side converter (RSC) regulates the slip power controlling the machine speed and torque while the grid-side converter (GSC) regulates the active power flow between rotor and grid maintain a constant DC-link voltage. Inductive filter is used on the GSC output in order to suppress converter harmonics on the network. Configuration of the overall DFIG wind turbine is shown in figure 1.

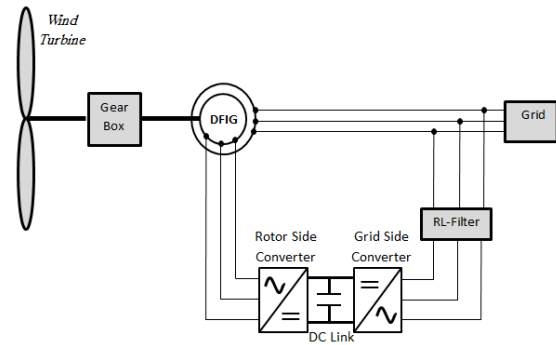

Fig.1 Simplified block diagram for DFIG wind energy conversion system.

In generator mode, active power flows from the network to the rotor in sub-synchronous operation and from the rotor to the network in super-synchronous operation. The converters size is determined by the desired speed range. Usually a $\pm 30\%$ slip enables a suitable operating region for wind turbine applications. At the same time, the use of bi-directional switches, IGBTs and anti-parallel diodes enable the phase displacement between converter output voltages and currents permitting the production of reactive power. The choice of the system orientation to the net voltage allows the regulation of reactive power independently from the active power control.

The DFIG control is performed in a reference frame rotating synchronously with the grid voltage vector

$$v_s = v_{ds} + v_{qs} \quad (1)$$

Orienting the synchronous rotating frame d-axis to the grid voltage vector enable the following simplifications

$$v_{ds} = v_s \quad (2)$$

$$v_{qs} = 0 \quad (3)$$

According to the voltage orientation the d-axis current is considered the active and the q-axis the reactive components, respectively. In this way the d-axis currents from the grid and rotor sides are responsible for respective the DC-link voltage and speed /torque controls. The q-axis currents are available in order to control the reactive power production on both converters.

The angle position of the grid voltage vector is obtained by a phase-locked-loop (PLL) explained in [10]. On the rotor side system is oriented to the slip angle. The rotor position θ_r , required for the slip angle $\theta_{sl} = \theta_s - \theta_r$, is also measured. This implication is illustrated in figure 2.

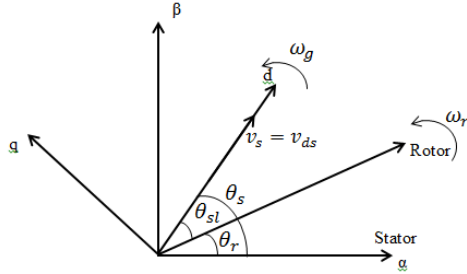

Fig. 2 Voltage orientation

3. SYSTEM DYNAMIC EQUATIONS

Since a DFIG is an electrical machine, it can be represented electrically using the equivalent circuit in the synchronous reference frame shown in figure 3. The control structure developed is based on the induction machine dynamic model whose voltage equations for the stator and rotor in the synchronously rotating frame are

$$v_s = R_s i_s + \frac{d\lambda_s}{dt} + j\omega_s \lambda_s \quad (4)$$

$$v_r = R_r i_r + \frac{d\lambda_r}{dt} + j\omega_{sl} \lambda_r \quad (5)$$

where

- v_s, v_r : stator and rotor voltage vectors (V),
- i_s, i_r : stator and rotor current vectors (A),
- λ_s, λ_r : stator and rotor flux linkage vectors (Wb),
- R_s, R_r : stator and rotor winding resistances (Ω),
- ω_s : is the synchronous speed (rad/s),
- $\omega_{sl} = \omega_s - \omega_r$: is the angular slip frequency of the generator (rad/s),
- ω_r : rotor electrical angular speed (rad/s).

where the flux linkage are given by the expressions

$$\lambda_s = L_s i_s + L_m i_r \quad (6)$$

$$\lambda_r = L_r i_r + L_m i_s \quad (7)$$

where

- $L_s = (L_{ls} + L_m)$: stator self-inductance (H),
- $L_r = (L_{lr} + L_m)$: rotor self-inductance (H),
- L_{ls}, L_{lr} : stator and rotor leakage inductances (H),
- L_m : magnetizing inductance (H), considering all values related to the stator side.

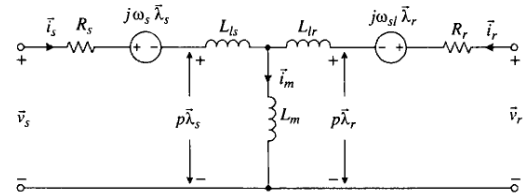

Fig. 3 DFIG equivalent circuit in the synchronous frame

For the outer speed/torque control loop, the motion equation which describes the dynamic behavior of the rotor mechanical speed in terms of mechanical and electromagnetic torque:

$$T_{em} - T_m = J \frac{d\omega_{mech}}{dt} + k_{Fr} \omega_{mech} \quad (8)$$

$$T_{em} = \frac{3P}{2} \text{Re}(j\lambda_s i_s^*) = -\frac{3P}{2} \text{Re}(j\lambda_r i_r^*) \quad (9)$$

where

- J : moment of inertia of the rotor (kgm^2),
- P : number of pole pairs,
- T_m : mechanical torque from the generator shaft (N.m),
- T_{em} : electromagnetic torque (N.m),
- ω_{mech} : rotor mechanical speed, $\omega_{mech} = \frac{\omega_r}{p}$ (rad/sec).

The grid inductive filter voltage equation is given by:

$$v_f = R_f i_g + L_f \frac{di_g}{dt} + v_g \quad (10)$$

where

- L_f : inductance of the grid side filter (H),
- R_f : resistive part of the grid side filter (Ω),
- v_g : grid voltage (V),
- i_g : currents flowing thorough the grid side converter's output (A),
- v_f : output voltages of the converter (V).

The outer voltage control loop on the GSC is accomplished by solving the power balance equation between DC-link and the grid side, neglecting the losses.

$$P_{dc} = P_g \rightarrow v_{dc} I_{dc} = \frac{3}{2} \text{Re}\{v_g i_g^*\} \quad (11)$$

and the DC-link voltage is found as

$$v_{dc} = \frac{1}{C_{dc}} \int (i_{g-dc} - i_{r-dc}) dt \quad (12)$$

4. OVERALL LOSS MODELLING

The quantity of each loss type can be described in the following set of equations (13)-(16).

The copper losses in the generator winding, P_{cu} :

$$P_{cu} = \frac{3}{2} R_s (i_{ds}^2 + i_{qs}^2) + \frac{3}{2} R_r (i_{dr}^2 + i_{qr}^2) \quad (13)$$

The friction losses, P_{Fr} :

$$P_{Fr} = k_{Fr} \omega_{mech}^2 \quad (14)$$

The RL filter losses, P_{Filter} :

$$P_{Filter} = R_{Filter} (i_{dg}^2 + i_{qg}^2) \quad (15)$$

The losses per each converter, P_{con} is given as follows:

$$P_{R_{con}} = R_{R_{con}} (i_{dr}^2 + i_{qr}^2), P_{G_{con}} = R_{G_{con}} (i_{dg}^2 + i_{qg}^2) \quad (16)$$

For derivation simplicity, constant resistance is estimated for each converter according to the operating point to express the average converter loss as follows [12]:

$$R_{con} = \begin{cases} 0.0347 pu, & I_{rms} \leq 0.2 pu \\ 0.0105 pu, & 0.2 pu < I_{rms} < 1 pu \end{cases} \quad (17)$$

5. LOSS MINIMIZATION OF DFIG

There are different techniques for controlling reactive power in DFIG circuit has been studied. The operation of an induction machine, where no contribution to the magnetization is done by the rotor circuit accomplished by setting the reactive reference control component of the rotor-side converter to zero ($i_{qr} = 0$). This leads to supplying the magnetizing current totally from the stator side. Another technique has been studied, when the rotor-side converter is mainly charge of adjusting the reactive power at the PCC by pumping reactive current through the rotor circuit. The stator currents does not have reactive current component ($i_{qs} = 0$).

By deriving the generator copper loss equation (13) in relative to the reactive component of the rotor current one can find the value for this current that minimizes the copper losses on the generator [11].

$$i_{qr_min_cu} = \frac{R_s x_m}{R_r x_s^2 + R_s x_m^2} v_s \quad (18)$$

As shown in (18), the optimum rotor reactive current component is a fixed value no matter what the operating point is. The grid-side converter is responsible for adjusting the power factor at the PCC. It is quite clear that this attitude considers only the copper losses inside the machine and neglects the losses due to converters and filter resistance. Therefore, for low-rating generators, it may give reasonable results but with larger generators (which is the case with windpower DFIGs), it does not lead to the optimal solution.

Based on the loss models of the previous section, firstly, the proposed strategy which considers the minimization of the total DFIG system losses was derived by optimizing the rotor reactive current and compared with the previously developed approaches used to control the reactive current flow in the DFIG circuit. Secondly, the operating points depending on the conditions of overall loss minimized operation of DFIG are choosing.

The total losses, P_{total} , by summing the equations from (13) to (16) as follows:

$$P_{total} = \frac{3}{2} R_s (i_{ds}^2 + i_{qs}^2) + R_g^* (i_{dg}^2 + i_{qg}^2) + R_r^* (i_{dr}^2 + i_{qr}^2) + k_{Fr} \omega_{mech}^2 \quad (19)$$

where:

$$R_g^* = R_{G_{con}} + R_{Filter}$$

$$R_r^* = \frac{3}{2} R_r + R_{R_{con}}$$

In order to obtain the optimal rotor reactive current (I_{qr_opt}), the total losses, equation (19), has to be differentiated with respect to i_{qr} and equating the derivative to zero, $\frac{\partial P_{total}}{\partial i_{qr}} = 0$. The optimal rotor reactive current is given by the following expression [12]:

$$I_{qr_opt} = \frac{B^2 X_m [v_s (R_s (A^2 + 1) + R_g^*) + A X_m R_g^* I_{dr}]}{R_r^* + B^2 X_m^2 [R_s (A^2 + 1) + R_g^*]} \quad (20)$$

$$\text{where: } A = \frac{R_s}{X_s}, \quad B = \frac{X_s}{(R_s^2 + X_s^2)}$$

As apparent from equation (20), the optimal rotor reactive current is dependent on the generator winding parameters as well as the filter and equivalent converter resistances. Moreover, it is also dependent on I_{dr} i.e., it varies according to the generator operating point.

The DFIG control block diagram supported by optimal rotor reactive current is shown in Figure 4. Based on equation (20), the optimization unit, is established to enforce the optimal rotor reactive

current. The power is controlled in order to follow the tracking characteristic.

The actual speed of the turbine measured and the corresponding mechanical power of the tracking characteristic is used as the reference power for the power control loop. The actual electrical output power, measured at the grid terminals of the wind turbine, is added to the total power losses (mechanical and electrical) and is compared with the reference power obtained from the tracking characteristic. A Proportional-Integral (PI) regulator is used to reduce the power error to zero. The output of this regulator is the reference rotor current i_{dr}^* that must be injected in the rotor by rotor side converter. The actual i_{qr} component current is compared with specified i_{qr}^* and the error is reduced to zero by a current regulator (PI). An outer control loop consisting of a DC voltage regulator, the output of the DC voltage regulator is the reference current i_{dg}^* . An inner current regulation loop consisting of a current regulator, the current regulator controls the voltage generated by the grid side converter from i_{dg}^* and specified i_{qg}^* .

6. SIMULATION RESULTS

To verify the proposed strategy, simulations carried out for a DFIG wind generation system using MATLAB/Simulink. The rating and parameters of the DFIG are listed in the appendix.

As shown in figure 5, it can be seen that every wind speed has to have a power characteristic (tracking characteristic) that a generator speed that gives a maximum output power. To capture the maximal power from wind turbines, it is desirable to follow the peak point curve by regulating generator speed.

Figure 6 shows the reactive power output performance, where a reasonably good decoupling is achieved during the simulation.

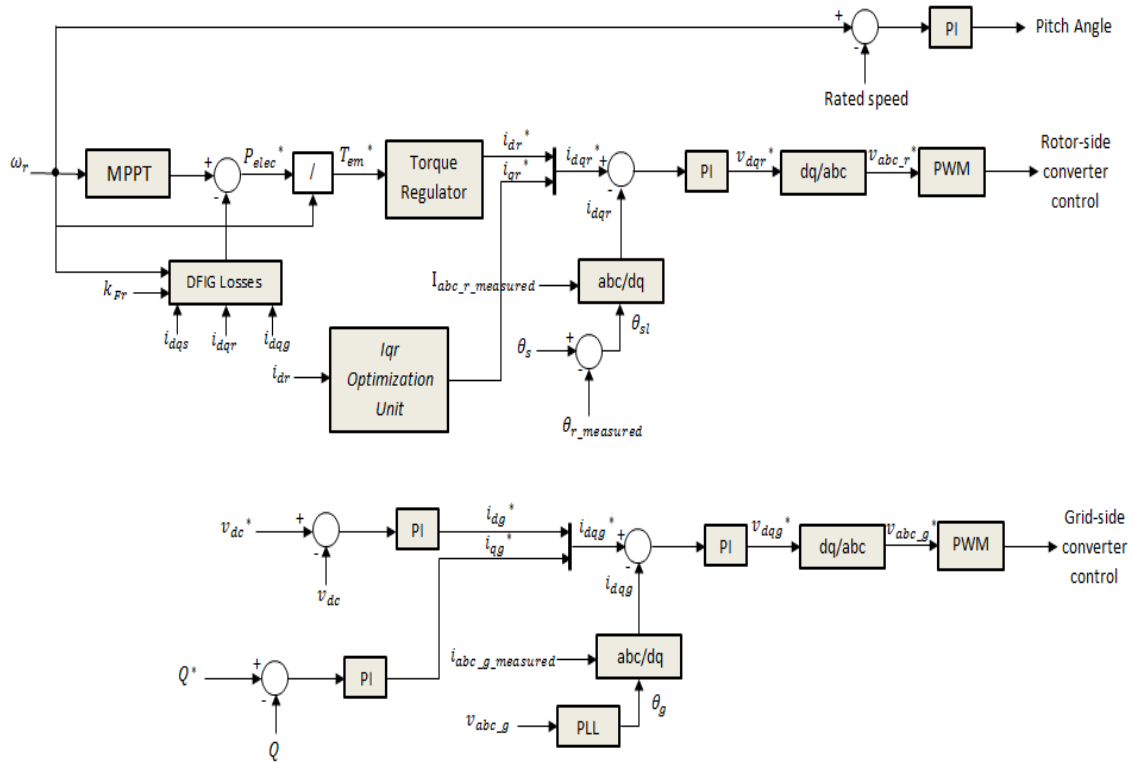

Fig.4 DFIG block diagram control

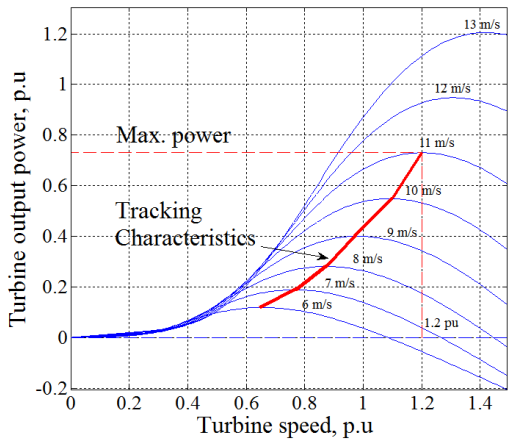

Fig. 5 Wind turbine power characteristics

Figure 7 illustrates the DC bus voltage performance, which is constant at specified reference value of 1200 V. Figure 8 shows the performance of rotor speed, which reaches to the synchronous speed of 1.2 p.u at $t = 2.5 \text{ sec}$, at which it enters the steady-state operation.

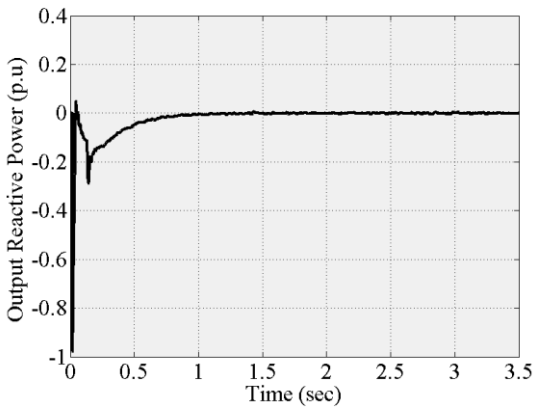

Fig. 6 Output reactive power in p.u.

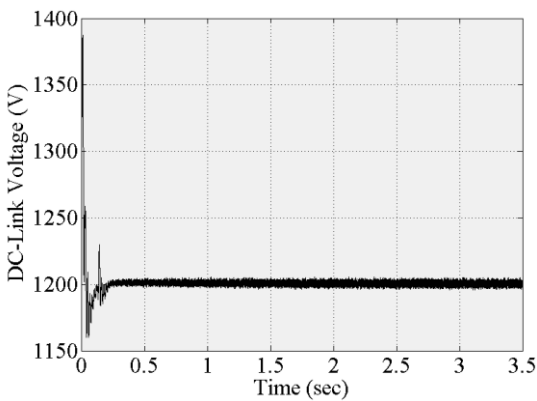

Fig. 7 DC-link voltage in volt

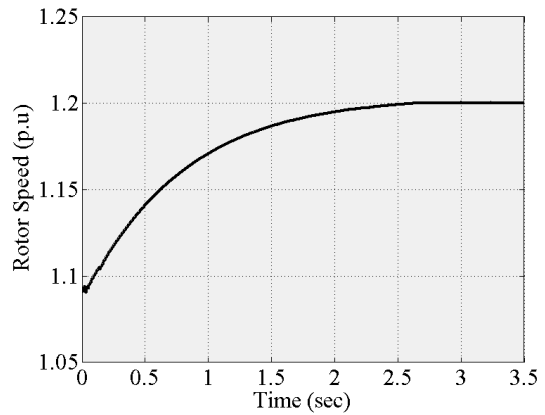

Fig. 8 Rotor speed in p.u

Figure 9 shows the computed results of the overall losses for unity power factor on the point of common coupling (PCC) for different strategies of reactive power control. The overall losses generated are plotted against the incident wind speed. The difference between the four strategies of controlling the reactive power flow is quite clear at rated wind speed (11m/s). The ($i_{qr} = 0$) technique gives the highest power losses. Slightly below is the situation for magnetization being carried out only by the rotor circuit ($i_{qs} = 0$). The minimum copper losses method is better than ($i_{qr} = 0$) and ($i_{qs} = 0$) techniques and is slightly over the optimal method since the losses of the filter and converters are not considered.

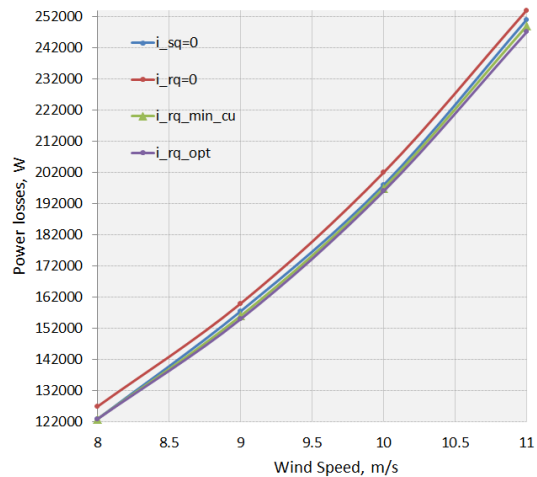

Fig.9 Total losses of unity power factor system

7. CONCLUSION

Based on analyzing the mathematical model and overall loss model of DFIG, A mathematical formula for optimum rotor reactive current to minimize the overall loss of the DFIG under unity power factor at the PCC and other operating points conditions have been proposed. This

method brings good improvement on the efficiency of the whole system compared with the normal operation condition of the DFIG and other methods. The presented modification and recommendation are to take the harmonics and magnetization losses neglected into account to analyse this optimization method more accurate.

8. REFERENCES

- [1] Tazil, M., and Kumar, V., ‘Three-phase doubly fed induction generators: an overview’, IET Electr. Power Appl., 2010, Vol. 4, Iss. 2, pp. 75–89.
- [2] Global Wind Energy Council: ‘Global Wind Energy Outlook 2012’, 2012, available at http://www.gwec.net/wpcontent/uploads/2012/11/GWEO_2012_lowRes.pdf, accessed November 2012.
- [3] Li, H., Chen, Z., and Pedersen, J. K., ‘Optimal power control strategy of maximizing wind energy tracking and conversion for VSCF doubly fed induction generator system’ in IEEE International Power Electronics and Motion Control Conference 2006. IPEMC’06, 14-16 August 2006, pp. 1-6.
- [4] Rabelo, B., and Hofmann, W., ‘Power flow optimisation and grid integration of wind turbines with the doubly-fed induction generator’. IEEE 36th Conf. Power Electronics Specialists, June 2005, pp. 2930–2936.
- [5] Rabelo, B., Hofmann, W., and Pinheiro, L., ‘Loss Reduction Methods for Doubly-Fed Induction Generator Drives for Wind Turbines’ in International Symposium on Power Electronics, Electrical Drives, Automation, and Motion, SPEEDAM’06, 2006, pp. S3-16 - S3-21.
- [6] Rabelo, B., and Hofmann, W., ‘Reactive power control in doubly-fed induction generators for wind turbines’ in Proc. IEEE Power Electron. Spec. Conf., Rhodes, Greece, 2008, pp. 106–112.
- [7] Rabelo B., Hofmann W., ‘Optimal active and reactive power control with the doubly fed induction generator in the MW-class wind-turbines’. Proc. Fourth IEEE Int. Conf. Power Electronics and Drive Systems, October 2001, vol. 1, pp. 53–58.
- [8] Rabelo B., Hofmann W., ‘Control of an optimized power flow in wind power plants with doubly-fed induction generators’. Proc. IEEE 34th Annual Power Electronics Specialist Conf., June 2003, vol. 4, pp. 1563–1568.
- [9] El-Fouly, T., El-Saadany, E., and Salama, M., ‘Voltage Regulation of Wind Farms Equipped with Variable-Speed Doubly-Fed Induction Generators Wind Turbines’ in IEEE

Power Engineering Society General Meeting 2007, Tampa, USA, 24-28 June 2007.

- [10] Abo-Khalil, A., Park, H., and Lee, D., ‘Loss Minimization Control for Doubly-Fed Induction Generators in Variable Speed Wind Turbines’. Proc. IEEE 33rd Annual Industrial Electronics Society Conf. (IECON), Nov. 5-8, 2007, Taipei, Taiwan.

9. APPENDICES

A-POWER COEFFICIENT

The power coefficient is approximated as [10]

$$C_p(\lambda, \beta) = 0.5176 \left(\frac{116}{\lambda_i} - 0.4\beta - 5 \right) \frac{-21}{\lambda_i} + 0.0068\lambda$$

$$\text{where } \frac{1}{\lambda_i} = \frac{1}{\lambda + 0.08\beta} - \frac{0.035}{\beta^3 + 1}$$

B-PARAMETERS OF DFIG WIND POWER SYSTEM

TABLE 1: WIND TURBINE PARAMETERS

MAIN PARAMETERS	VALUE
<i>Maximal power coefficient</i>	0.48
<i>Optimal tip speed ratio</i>	8.1
<i>Base wind speed (m/s)</i>	11
<i>Maximum power at base wind speed (p.u. of nominal mechanical power)</i>	0.73
<i>Base rotational speed (p.u. of base generator speed)</i>	1.2

TABLE 2: DFIG PARAMETERS

MAIN PARAMETERS	VALUE
<i>Rated power (MW)</i>	10
<i>Rated mechanical power (MW)</i>	9
<i>Rated voltage (V)</i>	575
<i>Pair of poles</i>	3
<i>Rated frequency (Hz)</i>	60
<i>Stator resistance (p.u)</i>	0.0071
<i>Rotor resistance (p.u)</i>	0.005
<i>Stator leakage inductance (p.u)</i>	0.171
<i>Rotor leakage inductance (p.u)</i>	0.156
<i>Mutual inductance (p.u)</i>	2.9
<i>Inertia constant (sec)</i>	5.04
<i>Friction factor (p.u)</i>	0.01
<i>Dc link capacitor (p.u)</i>	0.06
<i>Filter resistance (p.u)</i>	0.003
<i>Filter inductance (p.u)</i>	0.3